



## Batch Mixers

### Capacity

1 - 8000 gallons.

### Workheads

Interchangeable workheads available for all models.

### Materials of Construction

Product contact parts in 316L stainless steel. Non-standard materials such as carbon steel or Hastelloy available on request.

### Motor Specification

1 - 200 hp, TEFC, washdown duty, explosion proof, ATEX approved and stainless steel motors available as standard.

### Mounting

All mixers can be supplied with either a rectangular or circular flange for mounting on the vessel. Smaller models can be mounted on specially constructed mobile hydraulic floor stands.

### Sealing

Where sealing is required, lip seals and single or double mechanical shaft seals can be supplied.

### Cleaning

Simple, easy-to-clean construction.

# Batch Mixers

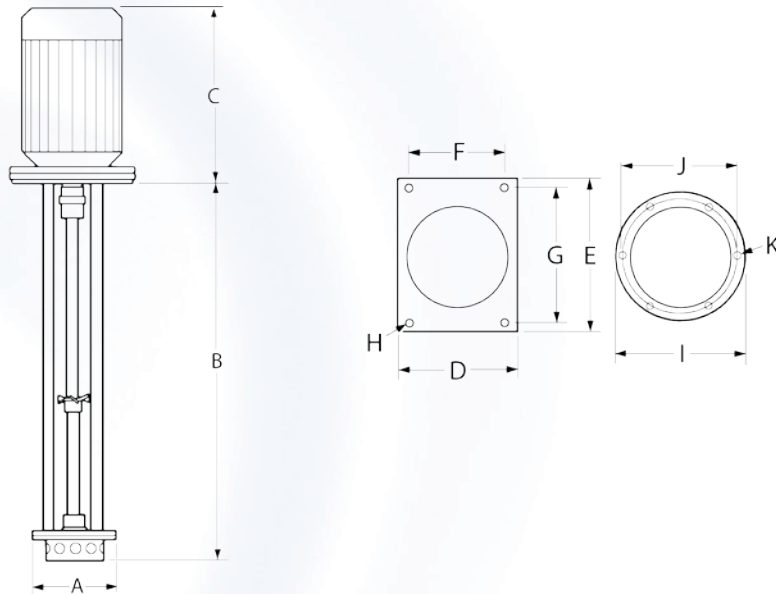

Model	HP	R.P.M.	A	B	TEFC B	EXPF C	D	E	F	G	H	I	J	K
BX/60	1.5	3600	4 5/8	24	11	12 1/2	9	9	7	8	4 x 3/8	10	8	6 x 3/8
DX/60	3	3600	6 1/4	27	13	14	10	10	8	9	4 x 3/8	10	8	6 x 3/8
EX/60	5.0	3600	6 1/2	31	13 1/2	15	12	12	10 1/2	10 1/2	4 x 7/16	13 1/4	11 1/2	6 x 7/16
FX/60	7.5	3600	6 1/2	41	15 3/4	17 1/2	12	16	10	14 1/2	4 x 7/16	16	14	6 x 7/16
GX15	15	3600	6 1/2	48	21	22 1/2	15	19	12	17	4 x 9/16	16	14	6 x 9/16
GX15	15	1800	11 1/4	48	21	22 1/2	15	19	12	17	4 x 9/16	16	14	6 x 9/16
GX25	25	3600	11 1/4	48	22 1/4	25 1/2	15	19	12	17	4 x 9/16	16	14	6 x 9/16
700X	20	3600	14 1/2	60	22 1/4	25 1/2	19	15	17	12	4 x 9/16	19	16	6 x 9/16
HX15	15	1200	16 1/2	+	22 1/4	25 1/2	20 1/2	17	18 3/4	15	4 x 1 1/16	23	20 1/2	6 x 13/16
HX40	40	1800	16 1/2	+	28 1/2	30	20 1/2	17	18 3/4	15	4 x 1 1/16	23	20 1/2	6 x 13/16
JX	25	1200	16 1/2	+	28 1/2	29 3/4	20 1/2	17	18 3/4	15	4 x 1 1/16	23	20 1/2	6 x 13/16
KX	from 50	1200	24	+	35	39	34	28	31	24	4 x 1 1/16	34	31 1/4	8 x 1 1/16

+ Length adjusted to suit vessel.

\* Capacities available on request.

All dimensions shown are in inches. The dimensions shown are approximate only and certified diagrams should be used for installation purposes. Silverson reserves the right to change dimensions and specifications without notice.